

10-30-1995

An Electrooptically Controlled Liquid-Crystal Diffraction Grating

J. Chen

Kent State University - Kent Campus

Philip J. Bos

Kent State University - Kent Campus, pbos@kent.edu

H. Vithana

Kent State University - Kent Campus

D. L. Johnson

Kent State University - Kent Campus

Follow this and additional works at: <https://digitalcommons.kent.edu/cpipubs>

Recommended Citation

Chen, J.; Bos, Philip J.; Vithana, H.; and Johnson, D. L. (1995). An Electrooptically Controlled Liquid-Crystal Diffraction Grating. *Applied Physics Letters* 67(18), 2588-2590. doi: 10.1063/1.115140 Retrieved from <https://digitalcommons.kent.edu/cpipubs/86>

This Article is brought to you for free and open access by the Department of Chemical Physics at Digital Commons @ Kent State University Libraries. It has been accepted for inclusion in Chemical Physics Publications by an authorized administrator of Digital Commons @ Kent State University Libraries. For more information, please contact digitalcommons@kent.edu.

An electro-optically controlled liquid crystal diffraction grating

J. Chen, P. J. Bos, H. Vithana, and D. L. Johnson

Physics Department and Liquid Crystal Institute, Kent State University, Kent, Ohio 44242

(Received 26 June 1995; accepted for publication 22 August 1995)

A structure for an electro-optically controlled liquid crystal diffraction grating is proposed, which can dramatically simplify the fabrication process of liquid crystal optical gratings. The structure consists of two alternating stripes. Each stripe is a hybrid liquid crystal cell with adjacent stripes oriented perpendicularly. This kind of electro-optically controlled diffraction grating in principle gives 100% diffraction efficiency and no polarization direction dependence. The detailed fabrication process is presented. © 1995 American Institute of Physics.

Large screen projectors with Schlieren optical systems require phase modulating control layers. Usually, these layers are based on mechanically deformable materials like oil films or a mirror on elastomer carriers.^{1,2} They modulate the phase by introducing optical path differences to the transmitted (or reflected) light. With a lens, the diffraction orders are focused in one plane where some orders are blocked, the rest being projected onto the screen. If the depth of phase grating varies, the light distribution between the orders changes and so the intensity on the screen varies. Commonly, dark field projection is used where the zeroth order is blocked so that the screen is dark if the control layer is not addressed. The principle of a Schlieren optical system is shown in Fig. 1.

Recently, it has been suggested that light-valve projectors using liquid crystal panels as a light modulator are an attractive way to produce large screen images.³⁻⁵ However, present methods to fabricate a nematic liquid crystal modulator have the following shortcomings. First, the diffraction efficiency has a strong polarization dependence. This means that at least 50% of incident light is lost when conventional sheet polarizers are used. Second, a high-resolution electrode pattern is needed to improve the shape of the modulated phase curve. Without grounding electrodes, the fringe electric field will destroy a square wave phase grating structure and introduce high-order harmonic terms which decreases the diffraction efficiency. If grounding electrodes are employed, electrode short will be a serious problem which makes them unpractical for application. One appropriate way to avoid these problems is to directly pattern the liquid crystal alignment layers to generate the LC diffraction grating. Some approaches have been tried. O'Callaghan and Handschy⁶ made electro-optic modulators using ferroelectric liquid crystal technology. Gibbons and Sun⁷ used an optically controlled alignment polymer to generate the LC grating structure. More recently, Bos *et al.*⁸ developed an optically active diffractive device based on the two-domain TN structure.

In this letter, a structure of an electro-optically controlled diffraction grating using liquid crystals is proposed and its fabrication process is dramatically simplified. This device in principle has the advantage of 100% diffraction efficiency as well as polarization independence. The detailed fabrication processes and our primary results of cell testing are presented in this letter.

The structure of the electro-optically controlled liquid

crystal diffraction grating is illustrated in Fig. 2. We have an alternating stripe structure, which is a prerequisite for forming optical diffraction devices. Each stripe is a hybrid liquid crystal cell. The orientations of the liquid crystal in two adjacent hybrid cells are perpendicular to each other. Any incident light can be decomposed into two components, polarized parallel and perpendicular to the stripe lines. These are the optical normal modes of the nematic medium. The alternating two vertical hybrid cells give us a periodic refractive index structure involving n_o and n_{eff} shown in the figure. n_o and n_{eff} are the ordinary and effective extraordinary refractive indices of the liquid crystal, respectively. This structure acts as a pure phase optical diffraction grating. Moreover, the depth of the modulated phase can be unambiguously controlled by cell voltage.

According to the structure shown in Fig. 2, one plate needs homeotropic anchoring. Many techniques can be used to achieve LC homeotropic alignment, for example, spin coating lecithin, silane surface treatment, and rotational SiO_x evaporation surface.⁹ We used a silane surfactant. Cleaned ITO coated glass substrates were spin coated with a 0.2% solution of silane (DMOAP) in isopropyl alcohol and water (1:2) in volume. These plates were then baked in a 100 °C oven for 1 h to allow the chemical reaction to complete.

For the other plate, one photolithography process is needed to pattern the alignment layer such that liquid crystals have perpendicular alignment directions in adjacent stripes. Double-rubbing, two-step SiO_x oblique evaporation¹⁰ and double photoinduced alignment techniques^{7,11} can be chosen

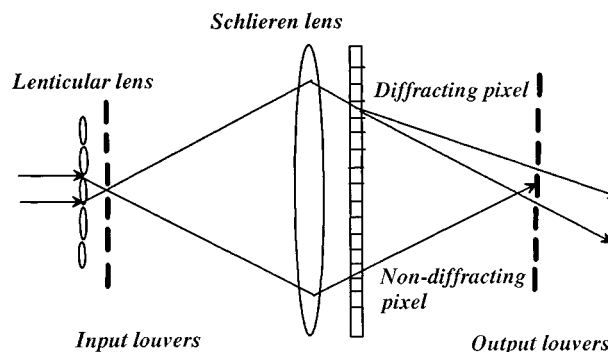

FIG. 1. Principle of a Schlieren optical projection system.

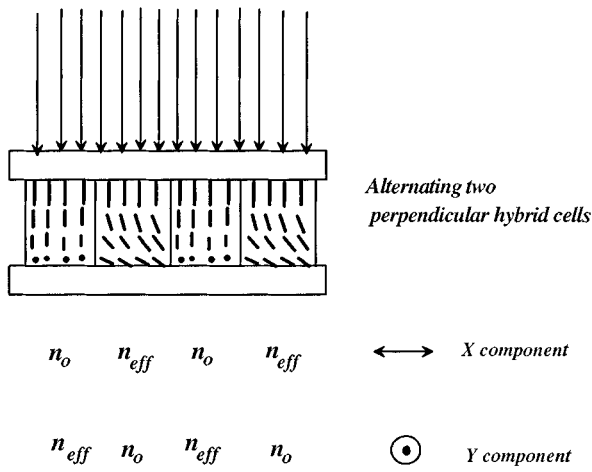

FIG. 2. New liquid crystal diffraction structure.

to get this alignment pattern. We used the double-rubbing technique¹⁰ because it is convenient for mass production. The polyimide (Nissan PI7311) first was spin coated on a glass substrate then baked around 250 °C for 2 h. Photolithography is carried out after the first rubbing process. Finally, the substrate is rubbed in the perpendicular direction and the photoresist (Shipley S1400-3) used as a mask is removed by acetone. The test cell of thickness 10 μm was filled with E7 from Merck company. The grating resolutions for test cells vary from 200 to 24 μm.

As shown in Fig. 2, for X and Y components, the relative phase difference of light passing through two adjacent stripes is equal to

$$\Delta\delta = \frac{2\pi}{\lambda} \int_0^d [n_{eff}(z) - n_o] dz, \quad (1)$$

$$n_{eff}(z) = n_o n_e / \sqrt{n_e^2 \sin^2[\theta(z)] + n_o^2 \cos^2[\theta(z)]},$$

where n_o and n_e are the ordinary and extraordinary refractive indices of the liquid crystal. $\theta(z)$ is the angle between the liquid crystal director and the xy plane. The director profile can be adjusted by the cell voltage thus varying $\Delta\delta$. If the relative phase difference is equal to $(2n + 1)\pi$, all diffractive spots are going to be at odd order positions which gives us 100% diffraction efficiency. However, if the relative phase difference is equal to $2\pi n$, no diffraction will occur. The $n = 0$ state corresponds to homeotropic alignment which can be approached with a high drive voltage ($V \sim 30$ V). The diffraction efficiency can be precisely controlled by the cell voltage. In order to achieve fast drive speeds, it is wise not to increase the cell thickness. Therefore, the phase difference in the diffraction state can be π and the nondiffraction state can be either 2π or zero (homeotropic state). At the no voltage state, under an approximation of $K_1 = K_3$, $\theta(z)$ is linear with z ,¹² i.e., $\theta(z) = (\pi/2 - \theta_0)z/d$, where K_1 and K_3 are the splay and bend elastic constants of the liquid crystal, respectively, and θ_0 is the liquid crystal pretilt angle at the bottom plate. Combining this relationship with Eq. (1), we can estimate the suitable cell thickness without missing desired states or introducing additional states.

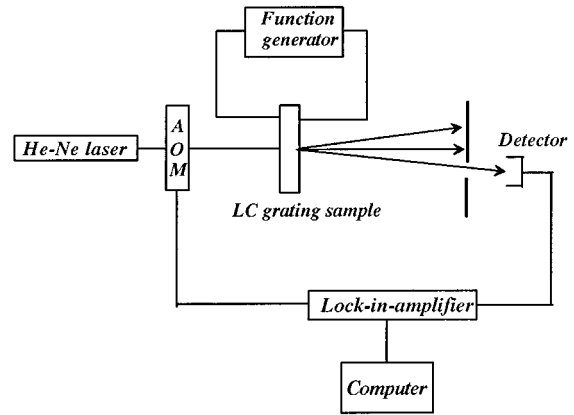

FIG. 3. Schematic of setup used to measure the electro-optical properties of test cells. (AOM) acoustic optical modulator.

The experimental setup for studying the electro-optical properties of the grating is sketched in Fig. 3. The He-Ne laser beam was modulated by an acoustic optical modulator (AOM). The transmitted beam passing through a pinhole was collected by a detector which was connected to a lock-in amplifier. An ac voltage at 1 kHz was provided by a function generator.

The microscope pictures of two test cells with stripe widths 24 and 200 μm, respectively, are shown in Fig. 4. The nice periodic structures indicate a good liquid crystal alignment. Figure 5 shows the transmission behavior of zero- and first-order diffraction of a test cell with a stripe width of 75

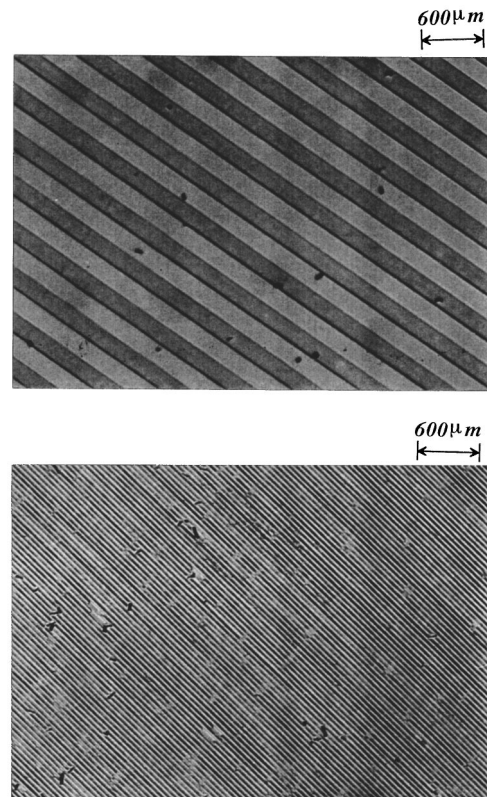

FIG. 4. Micrographs of two test cells with stripe widths of 200 and 24 μm, respectively.

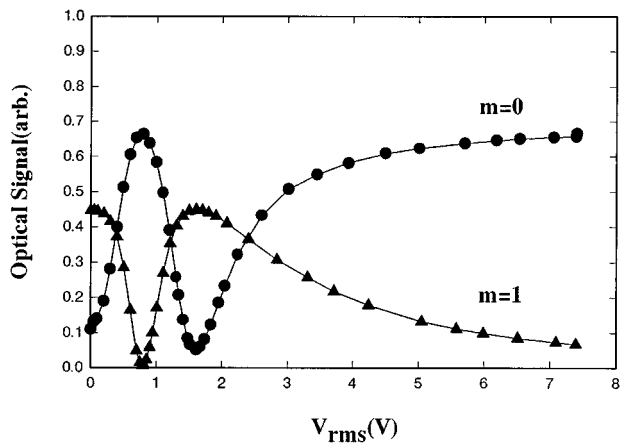

FIG. 5. Electro-optical data for zero and first diffraction order. The test cell stripe width is $75 \mu\text{m}$ and unpolarized laser light is used.

μm under unpolarized incident laser light. As expected, the $m=0$ and $m=1$ orders mirror each other as a function of applied voltage. The transmission peak and valley in the zero order curve correspond to a phase difference of 2π (minimum diffraction) and π (maximum diffraction), respectively. Figure 6 illustrates voltage dependent behavior of the first order ($m=1$) for two input polarizations, one parallel to the stripes, the other perpendicular. This result indicates that the test cell has very good polarization independence of diffraction.

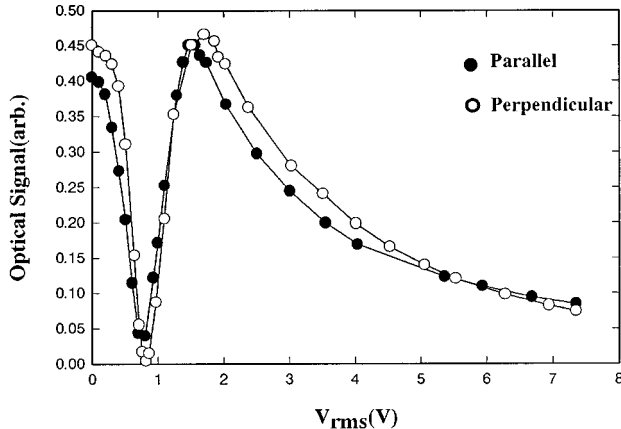

FIG. 6. Electro-optical data of first-order diffraction for the same test cell as Fig. 5 under two input polarization directions, one parallel to stripes and one perpendicular.

The test cells fabricated gave us nearly perfect diffraction performance. The following factors should be considered to make grating cells have perfect diffraction states. First of all, the perfect diffraction state requires a pure 180° phase grating along both the x and y directions (see Fig. 2). This means the geometry of two perpendicular hybrid cells should be identical. It is hard to get the same liquid crystal pretilt angle in both regions because of a photolithography process involved and the vagaries of rubbing. Secondly, disclination lines at the boundary of hybrid liquid crystal stripes reduce the diffraction efficiency. Furthermore, the width of the stripes should be identical and the second rubbing direction should be strictly perpendicular to the first one. We believe the difference in pretilt angle in adjacent stripes is the main impediment to a perfect diffraction state.

A proposed structure for an electro-optically controlled liquid crystal diffraction grating in principle can provide 100% diffraction efficiency and polarization direction independence. The structure consists of two alternative stripes. Each stripe is a hybrid liquid crystal cell; the orientations of the liquid crystal in two adjacent hybrid cells are perpendicular. The test cells confirm the principles. The simple fabrication process makes it competitive for diffractive light valves for large screen projectors. Impediments to a perfect diffraction state are also discussed.

The authors wish to thank Doug Bryant for his help in engineering the cell construction. This work is financially supported by Office of Naval Research under Grant No. N00014-94-0270 and by the Advanced Liquid Crystalline Optical Materials (ALCOM) program under Grant No. DMR-8920147.

- ¹W. E. Glenn, New Color Projection System, *J. Opt. Soc. Am.* **48**, 841 (1958).
- ²W. E. Glenn, *SID Digest XVII*, 72(1987).
- ³Y. Hori, K. Asdi, and M. Fukai, *IEEE Trans. Electron Devices* **ED-26**, 1734 (1979).
- ⁴M. W. Fritsch, H. Wohler, G. Haas, and D. A. Mlynski, *IDRC'88*, p. 199.
- ⁵M. W. Fritsch, H. Wohler, G. Haas, and D. A. Mlynski, *IDRC'90*, p. 10.
- ⁶M. J. O'Callaghan and M. A. Handschy, *Opt. Lett.* **16**, 770 (1991).
- ⁷W. M. Gibbons and S. T. Sun, *Appl. Phys. Lett.* **65**, 2542 (1994); Also see W. M. Gibbons, P. J. Shannon, and S. T. Sun, *Liq. Cryst. Today* **4**, 1 (1994).
- ⁸P. J. Bos, J. Chen, J. W. Doane, B. Smith, C. Holton, and W. Glenn, *SID Digest XXVI*, 601 (1995).
- ⁹T. Uchida and H. Seki, *Liquid Crystals, Applications and Users*, edited by B. Bahadur (World Scientific, London, 1990), Vol. 3, p. 1.
- ¹⁰J. Chen, P. J. Bos, D. B. Bryant, D. L. Johnson, S. H. Jamal, and J. R. Kelly, *SID Digest XXVI*, 865 (1995).
- ¹¹M. Schadt, K. Shmitt, V. Kozinkov, and V. Chigrinov, *Jpn. J. Appl. Phys.* **31**, 2155 (1992).
- ¹²P. G. de Gennes, *The Physics of Liquid Crystals*, 2nd ed. (Oxford Science, Oxford, 1993).